

Description	The pneumatic proportional pressure regulator controls the outlet pressure in a complete closed loop servo system in proportion to an digital IO-Link command signal. By using the IO-Link Master the valve can be adapted to special applications and optimize the the response time, the overshoot and the precision of the valve. The valve has no constant bleed. At absence of input signal or supply voltage the pressure of the valve stands.		
Media	dry, lubricated, unlubricated and 50 µm filtered compr. air or non-corrosive gases		
Command signal	Digital command signal in 1mbar steps (0-10000 = 0-10 bar)	Control IO-Link (Class A)	
Hysteresis	1,5% FS	Supply voltage 24 VDC	Software: IODD (necessary)
Linearity	1,5% FS	Electrical connector M12, 5-pin	
Repeatability	1,5% FS	Protection class IP65	
Minimum Command signal	0,5% FS	Current consumption 180 mA	
Minimum Outlet Pressure	1,0% FS	Power consumption 3,8 W (< 1W if regulated)	
Temperature range	0-60 °C Media and Ambient		
Material	Body: aluminium	Inner valve: POM (Polyacetal)	Elastomer: NBR
Mounting position	any, preferably perpendicular		

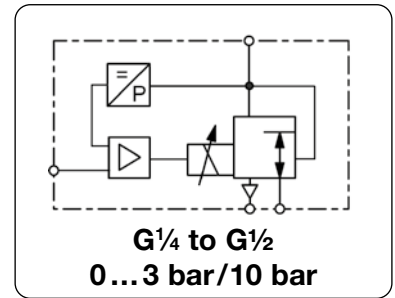

Dimensions			K _v - value	Flow rate (m ³ /h)	Supply pressure l/min	Supply pressure bar ⁻¹	Connection thread G	Pressure range bar	Order number	E*
A	B	C								

Proportional pressure regulator						Supply 24 V DC via IO-Link master without coupling socket		PIO	
52	115	73	0.43	28,2	470	4	G ¹ / ₄	0 ... 3	PIO2-03
						7	G ¹ / ₄	0 ... 6	PIO2-06
						11	G ¹ / ₄	0 ... 10	PIO2-10
66	129	89	1.2	78	1300	4	G ³ / ₈	0 ... 3	PIO3-03
						7	G ³ / ₈	0 ... 6	PIO3-06
						11	G ³ / ₈	0 ... 10	PIO3-10
66	144	102	4.8	312	5200	4	G ¹ / ₂	0 ... 3	PIO4-03
						7	G ¹ / ₂	0 ... 6	PIO4-06
						11	G ¹ / ₂	0 ... 10	PIO4-10



PIO

Special options, add the appropriate letter or number

Display	PIO-... B
for oxygen	PIO-... 15

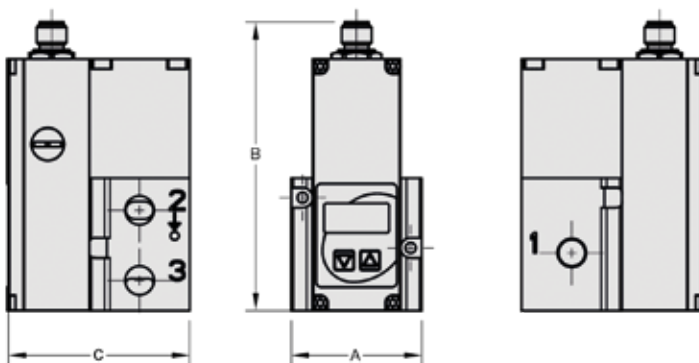

- 1: inlet
- 2: outlet
- 3: exhaust

PIO

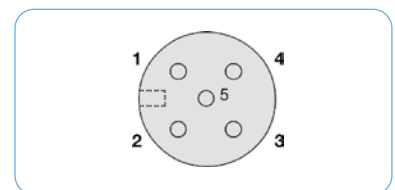

view from solder pin side

Pin	Description
1	24V supply voltage
2	not occupied
3	supply ground
4	C/Q
5	not occupied
Housing	EMC shield

connection plan

*1 To use the valve, you need the IODD
P1 = at least 1 bar higher than the maximum outlet pressure

* Product group

PDF CAD
www.aircom.net



Order example:
PIO2-03

